

**OBSTACLE AVOIDANCE
ROBOTIC VEHICLE**

using

ULTRASONIC SENSOR

and

ARDUINO

CONTROLLER

ABSTRACT

Obstacle avoidance is one of the most important aspects of mobile robotics. Without it, robot movement would be very restrictive and fragile. This project proposes robotic vehicle that has an intelligence built in it such that it directs itself whenever an obstacle comes in its path. So, to protect the robot from any physical damages.

This can be design to build an obstacle avoidance robotic vehicle using ultrasonic sensors for its movement. A micro-controller(AT mega 328P) is used to achieve the desired operation.

An ultrasonic sensor is used to detect any obstacle ahead of it and sends a command to the microcontroller. Depending on the input signal received, the micro-controller redirects the robot to move in an alternate direction by actuating the motors which are interfaced to it through a motor driver.

ACKNOWLEDGEMENT

It is my proud privilege and duty to acknowledge the kind of help and guidance received from several people in preparation of this report. Apart from my own, the success of this report depends largely on the encouragement and guidelines of many others. It would have not been possible to prepare this report in this form without their valuable help, co- operation and guidance.

I would like to express my deep sense of gratitude to our **Praveen sir, Geethanjali college of engineering and technology** for his motivation and for creating an inspiring atmosphere in college by providing state of the art facilities for preparation and delivery of this report..

Last but not least, I would like to put forward my heartfelt acknowledgement to all my project mates who have directly or indirectly provided their overwhelming support during my project work and the development of this report.

22R11A04A3 B. Hemanth Reddy
22R11A04C3 K. Manish Datta

CONTENTS

Chapter 1:

Introduction 1

Chapter 2:

Literature Review 3

Chapter 3:

Design & Hardware 5

Chapter 4:

Block Diagram 7

Chapter 5:

Working 11 - 16

Chapter 6:

Circuit Diagram 17

Chapter 7:

Applications 19

Chapter 8:

Experimental Results 21

Chapter 9:

Program 23 - 25

Chapter 10:

Conclusion 27

Chapter 11:

Reference 30

CHAPTER NO: 1

INTRODUCTION

INTRODUCTION

Robotics is part of today's communication. In today's world ROBOTICS is fast growing and interesting field. It is simplest way for latest technology modification. Now a days communication is part of advancement of technology, so we decided to work on ROBOTICS field, and design something which will make human life simpler in day today aspect. Thus we are supporting this cause.

An obstacle avoiding robot is an intelligent device, which can automatically sense and overcome obstacles on its path. Obstacle Avoidance is a robotic discipline with the objective of moving vehicles on the basis of the sensorial information. The use of these methods front to classic methods (path planning) is a natural alternative when the scenario is dynamic with an unpredictable behaviour. In these cases, the surroundings do not remain invariable, and thus the sensory information is used to detect the changes consequently adapting moving. It will automatically scan the surrounding for further path.

This project is basic stage of any automatic robot. This ROBOT has sufficient intelligence to cover the maximum area of provided space. It has a ultrasonic sensor which are used to sense the obstacles coming in between the path of ROBOT. It will move in a particular direction and avoid the obstacle which is coming in its path. We have used two D.C motors to give motion to the ROBOT. The construction of the ROBOT circuit is easy and small .The electronics parts used in the ROBOT circuits are easily available and cheap too.

CHAPTER NO :2

LITERATURE REVIEW

LITERATURE REVIEW:

We reviewed different obstacle detecting robot mechanisms that have been built by a lot of students and other practitioners that are in existence. For an autonomous mobile robot performing a navigation-based task in a vague environment, to detect and to avoid encountered obstacles is an important issue and a key function for the robot body safety as well as for the task continuity. Obstacle detection and avoidance in a real world environment that appears so easy to humans is a rather difficult task for autonomous mobile robots and is still a well- researched topic in robotics. In many previous works, a wide range of sensors and various methods for detecting and avoiding obstacles for mobile robot purpose have been proposed. Good references related to the developed sensor systems and proposed detection and avoidance algorithms can be found. Based on these developed sensor systems, various approaches related to this work can be grouped

Robots need miscellaneous of sensors to obtain information about the world around them. Sensors will help detect position, velocity, acceleration and range for the object in the robot's workspace. There is a variety of sensors used to detect the range of an object. One of the most common range finders is the ultrasonic transducer.

Vision systems are also used to greatly improve the robot's versatility, speed and accuracy for its complex and difficult task. Electronic signals are sent to a mobile robot's motor controllers and auditory signals can guide the blind traveller around the obstacles the developed robot uses ultrasonic range finder for detection and mapping to avoid collision with the unexpected obstacles.

“Obstacle-avoiding robot with IR motion Sensors” has been designed and developed ,robot platform was not designed for specific task but as a general wheeled autonomous platform. It can therefore be used for educational, research or industrial implementation. Students can use it to learn the microcontroller programming using C++, Arduino Uno compiler, IR sensors characteristics, motor driving circuit and signal condition circuit design. Research on obstacle avoidance robot at the polytechnic level can help students to develop communication, technical skills and teamwork. The design of such robot is very flexible and various methods can be adapted for another implementation. It shows that PIR sensors are more sensitive compared to IR sensors while detecting human being

CHAPTER NO: 3

DESIGN & HARDWARE REQUIREMENTS

Design:

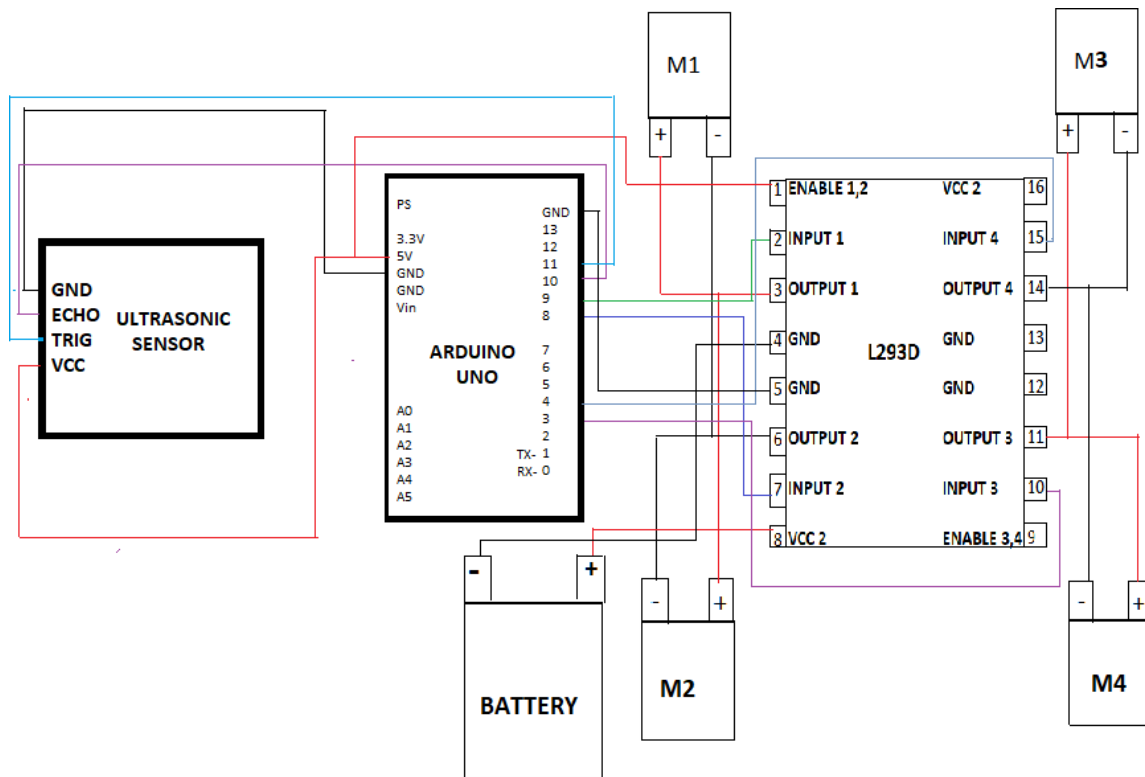

Hardware:

- **Arduino UNO**
- **Ultrasonic sensor**
- **DC Motors**
- **Motor driver IC (L293D)**
- **Battery (9V)**
- **Jumper Wires**
- **Chassis**
- **Wheels**

CHAPTER NO:4

BLOCK DIAGRAM

BLOCK DIAGRAM

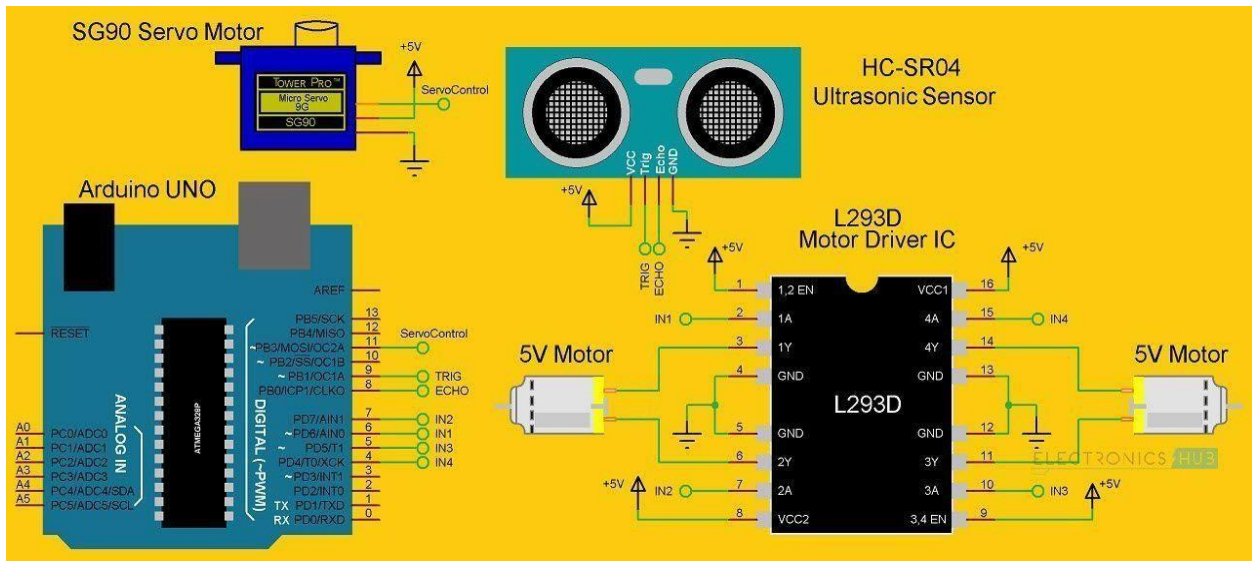

The basic block diagram of the obstacle avoiding car is shown in above figure. Mainly this block diagram consists of the following essential blocks.

1. Arduino uno
2. Ultrasonic sensor
3. Motor driver(L293D)

1) Arduino uno -

Arduino Uno is an ATmega 328p Microcontroller based prototyping board. It is an open source electronic prototyping platform that can be used with various sensors and actuators. It is used for controlling all the operation and assign task to each device.

2) Ultrasonic sensor -

It is an Ultrasonic Range Finder Sensor. It is a non-contact based distance measurement system and can measure distance of 2cm to 4m. Ultrasonic sensor is mainly use to detect the obstacle

3) Motor driver -

It is a motor driver which can provide bi-directional drive current for two motors.

CHAPTER NO:5

WORKING

Working Principle:

The obstacle avoidance robotic vehicle uses ultrasonic sensors for its movements. Arduino is used to achieve the desired operation. The motors are connected through motor driver IC to Arduino. The ultrasonic sensor is attached in front of the robot.

Whenever the robot is going on the desired path the ultrasonic sensor transmits the ultrasonic waves continuously from its sensor head. Whenever an obstacle comes ahead of it the ultrasonic waves are reflected back from an object and that information is passed to the arduino. The arduino controls the motors left, right, back, front, based on ultrasonic signals. In order to control the speed of each motor pulse width modulation is used (PWM).

When ultrasonic sensor detect the object which is kept inside the path it will send the signal toward the arduino uno and according to that it will rotate the motor M3 & M4 in forward direction and rotate the motor M1 & M2 in reverse direction such way that the car get moving in left direction .

Similarly in every time when ever an obstacle is found to be in path of car it will detect it and rotate the car in left direction to avoid the obstacle.

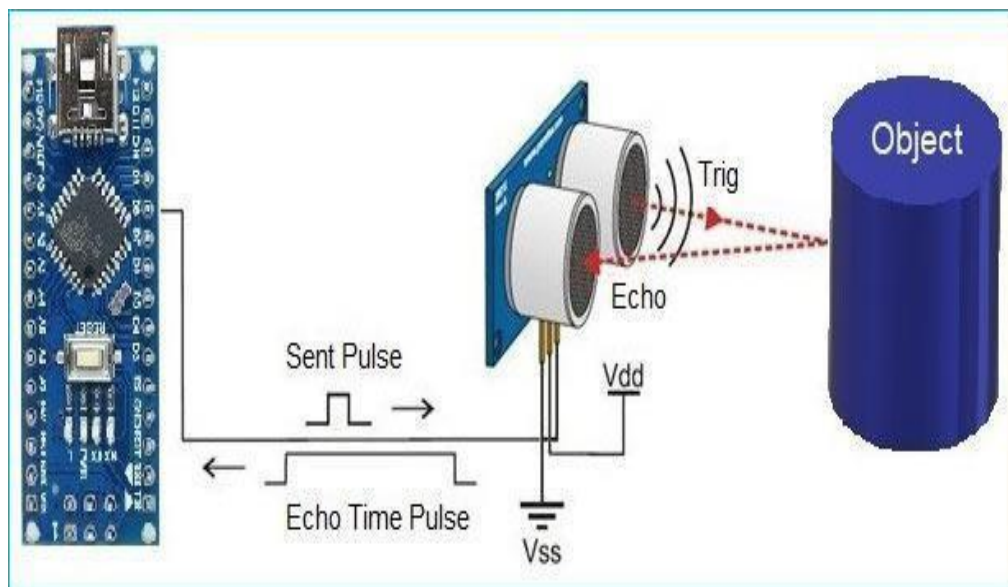

ARDUINO UNO:



Arduino/Genuino Uno is a microcontroller board based on the ATmega328P. It has 14 digital input/output pins (of which 6 can be used as PWM outputs), 6 analog inputs, a 16 MHz quartz crystal, a USB connection, a power jack, an ICSP header and a reset button. It contains everything needed to support the microcontroller; simply connect it to a computer with a USB cable or power it with a AC-to-DC adapter or battery to get started.. You can tinker with your UNO without worrying too much about doing something wrong, worst case scenario you can replace the chip for a few dollars and start over again. "Uno" means one in Italian and was chosen to mark the release of Arduino Software (IDE) 1.0. The Uno board and version of Arduino Software (IDE) were the reference versions of Arduino, now evolved to newer releases. The Uno board is the first in a series of USB Arduino boards, and the reference model for the Arduino platform; for an extensive list of current, past or outdated boards see the Arduino index of boards.

Motor Drivers (L293D IC)

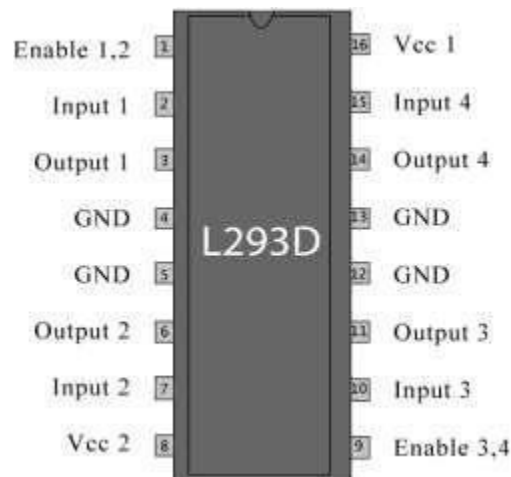

- Motor drivers take a low current control signal but provide a higher current signal, thus acting as a current amplifier. The higher current signal drives the motors. L293D is a motor driver that allows direct current (DC) motor to drive on either direction. It contains two inbuilt H-bridge driver circuits . To rotate the motor in clockwise or anticlockwise direction, voltage need to change its direction. H-bridge is a circuit that allows voltage to be flown in either direction. Hence H-bridge IC are ideal for driving a DC motor .
- Here are 4 input pins for L293d, pin 2,7 on the left and pin 15 ,10 on the right as shown on the pin diagram. Left input pins will regulate the rotation of motor connected across left side and right input for motor on the right hand side. The motors are rotated on the basis of the inputs provided across the input pins as LOGIC 0 or LOGIC 1. For rotating the motor in clockwise direction the input pins has to be provided with Logic 1 and Logic 0. Enable pins 1 and 9 (corresponding to the two motors) must be high for motors to start operating. When an enable input is high, the associated driver gets enabled. As a result, the outputs become active and work in phase with their inputs. Similarly, when the enable input is low, that driver is disabled, and their outputs are off and in the high-impedance state.



Motor (100rpm/ 12V DC Motor)



- The obstacle detection and avoiding robot uses two 200rpm and 12V DC geared motors. The motor used has a 6mm shaft diameter with internal holes. The internal holes are for easy mounting of the wheels by using screws. It is an easy to use low-cost motor for robotics application
- An Electric DC motor is a machine which converts electric energy into mechanical energy. The working of DC motor is based on the principle that when a current-carrying conductor is placed in a magnetic field, it experiences a mechanical force.

The direction of mechanical force is given by Fleming's Left-hand Rule and its magnitude is given by $F = BIL$ Newton.

- DC motors are seldom used in ordinary applications because all electric supply companies furnish alternating current.

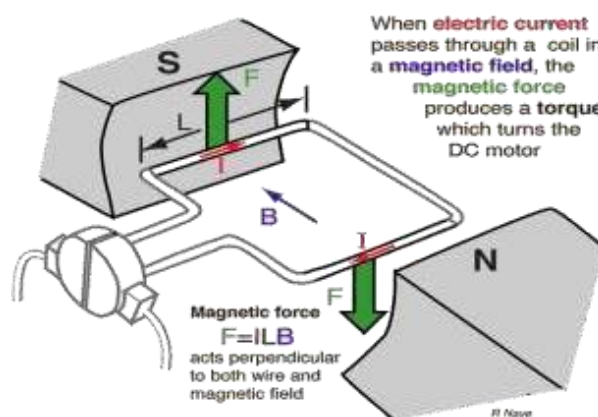

ULTRASONIC SENSOR



- An Ultrasonic sensor is a device that can measure the distance to an object by using sound waves. It measures distance by sending out a sound wave at a specific frequency and listening for that sound wave to bounce back. By recording the elapsed time between the sound wave being generated and the sound wave bouncing back, it is possible to calculate the distance between the sonar sensor and the object.
- It emits an ultrasound at 40 000 Hz which travels through the air and if there is an object or obstacle on its path It will bounce back to the module. Considering the travel time and the speed of the sound you can calculate the distance.
- The HC-SR04 Ultrasonic Module has 4 pins, Ground, VCC, Trig and Echo. The Ground and the VCC pins of the module needs to be connected to the Ground and the 5 volts pins on the Arduino Board respectively and the trig and echo pins to any Digital I/O pin on the Arduino Board.
- In order to generate the ultrasound you need to set the Trig on a High State for 10 μ s. That will send out an 8 cycle sonic burst which will travel at the speed sound and it will be received in the Echo pin. The Echo pin will output the time in microseconds the sound wave traveled.

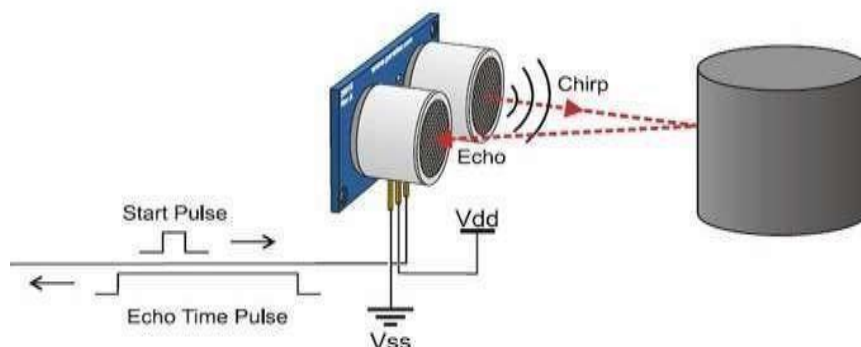

CHAPTER NO:6

CIRCUIT DIAGRAM

CIRCUIT DIAGRAM

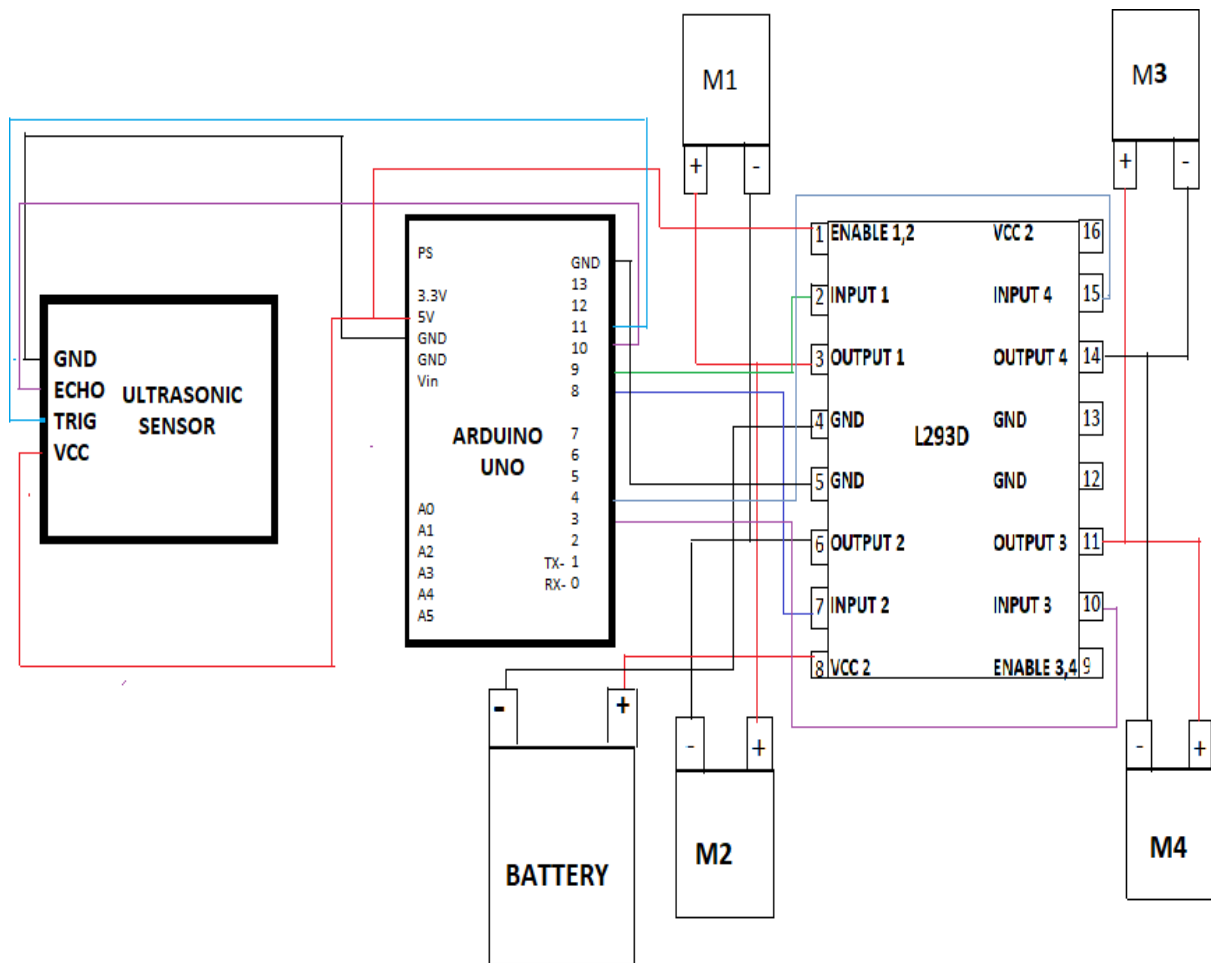

CHAPTER NO:7

APPLICATIONS

APPLICATIONS

This device has application in surveying different landscapes and mapping them. It can also be used in commercial devices like

- Automated lawn mover
- Smart room cleaner etc
- Obstacle avoiding robots can be used in almost all mobile robot navigation systems.
- They can also be used in dangerous environments, where human penetration could be fatal.
- Unmanned vehicle driving
- Mining Vehicle that uses Obstacle Detection

CHAPTER NO:8

EXPERIMENTAL RESULTS

EXPERIMENTAL RESULT

The result is obtained for obstacle avoidance robot using Arduino, if the robot moves forward if any obstacle detect it check for other directions and moves where there is no obstacles it moves in forward direction, to sense the obstacle ultrasonic sensor is used. We used servo motor to rotate the ultrasonic sensor.

The working principle of the robot is transmitting sensed signal to the microcontroller to control the DC motors for obstacle avoidance. The direction of the motors to move either clockwise or anti-clockwise directions as provided by the microcontroller. Ultrasonic sensor detect a moving object while IR sensor does not detect any object, the robot will move backward (motor 1 and motor 2 counter clockwise).

The sensor also detects object, the robot will stop (motor 1 and motor 2 OFF). After 50 ms, motor 1 will move clockwise and the robot will turn left. After 500 ms, the robot will move forward (motor 1 and motor 2 clockwise) and after 1000ms, both motors will stop. From the flow chart in Figure 10, it shows that the IR sensors are very effective in sensing signals in their path for the obstacle avoiding robots to evade obstacles in its path.

CHAPTER NO: 9

PROGRAM

// OBSTACLE AVOIDING CAR:

First define trig and echo pin of HC-SR04 in the program.

```
int trigPin = 9; // trig pin of HC-SR04
int echoPin = 10; // Echo pin of HC-SR04
```

Define pins for input of LM298N Motor Driver Module.

The LM298N has 4 data input pins used to control the direction of motor connected to it.

```
int revleft4 = 4; //REVERSE motion of Left motor
int fwdleft5 = 5; //FORWARD motion of Left motor
int revright6 = 6; //REVERSE motion of Right motor
int fwdright7 = 7; //FORWARD motion of Right motor
```

LM298N Motor Driver Module

In *setup()* function, define the data direction of utilized GPIO pins.

The four Motor pins and Trig pin is set as OUTPUT and Echo Pin is set as Input.

```
pinMode(revleft4, OUTPUT); // set Motor pins as output
pinMode(fwdleft5, OUTPUT);
pinMode(revright6, OUTPUT);
pinMode(fwdright7, OUTPUT);
pinMode(trigPin, OUTPUT); // set trig pin as output
pinMode(echoPin, INPUT); //set echo pin as input to capture reflected
```

In *loop()* function, get the distance from HC-SR04 and based on the distance move the motor direction.

The distance will show the object distance coming in front of the robot.

The Distance is taken by bursting a beam of ultrasonic up to 10 us and receiving it after 10us.

```
digitalWrite(trigPin, LOW);
delayMicroseconds(2);
digitalWrite(trigPin, HIGH); // send waves for 10 us
delayMicroseconds(10);
duration = pulseIn(echoPin, HIGH); // receive reflected waves
distance = duration / 58.2; // convert to distance
delay(10);
```

If the distance is greater than the defined distance means there is not obstacle in its path and it will moving in forward direction.

```
if (distance > 19)
{
digitalWrite(fwdright7, HIGH); // move forward
digitalWrite(revright6, LOW);
digitalWrite(fwdleft5, HIGH);
digitalWrite(revleft4, LOW);
}
```

If the distance is less than the defined distance to avoid obstacle means there is some obstacle ahead.

So in this situation robot will stop for a while and move backwards after that again stop for a while and then take turn to another direction.

```
if (distance < 18)
{
digitalWrite(fwdright7, LOW); //Stop
digitalWrite(revright6, LOW);
digitalWrite(fwdleft5, LOW);
digitalWrite(revleft4, LOW);
delay(500);
digitalWrite(fwdright7, LOW); //movebackward
digitalWrite(revright6, HIGH);
digitalWrite(fwdleft5, LOW);
digitalWrite(revleft4, HIGH);
delay(500);
digitalWrite(fwdright7, LOW); //Stop
digitalWrite(revright6, LOW);
digitalWrite(fwdleft5, LOW);
digitalWrite(revleft4, LOW);
delay(100);
digitalWrite(fwdright7, HIGH);
digitalWrite(revright6, LOW);
digitalWrite(revleft4, LOW);
digitalWrite(fwdleft5, LOW);
delay(500);
}
```

CHAPTER NO: 10

CONCLUSION

CONCLUSION

The goal of our project is to create a autonomous robot which intelligently detects the obstacle in his path and navigate according to the actions we set for it.

The above Arduino controller and ultrasonic sensor were studied and the HcSR-04 ultrasonic sensor was selected, as the controlling result are satisfying for its use in the automobile prototype system bring developed. It was used to sense the obstacle and avoidance them.

On successful implementation of obstacle avoidance algorithm was successfully carried out too with minimal errors, by coding the algorithm in python. Obstacle avoidance is a very good application to be used in vehicle preventing many accidents and loss of life.

This project developed an obstacle avoiding robot to detect and avoid obstacles in its path. The robot is built on the Arduino platform for data processing and its software counterpart helped to communicate with the robot to send parameters for guiding movement. For obstacle detection, three ultrasonic distance sensors were used that provided a wider field of detection. The robot is fully autonomous and after the initial loading of the code, it requires no user intervention during its operation.

When placed in unknown environment with obstacles, it moved while avoiding all obstacles with considerable accuracy. In order to optimize the movement of the robot, we have many considerations for improvement. However, most of these ideas will cost more money and time as well. In future cameras can be used to detect the obstacle however, it is better to get CCD or industrial use ones to get clear and fast pictures. Even the ones we mentioned in the camera holder part will be better because of the special software.

CHAPTER NO: 11

REFERENCES

REFERENCES

[1] Amir attar, aadilansari, abhishek desai, shahid khan, dip ashisonawale “line follower and obstacle avoidance bot using arduino” International Journal of Advanced Computational Engineering and Networking, vol. 2, pp. 740-741, August 1987.

[2] Aniket D. Adhvaryu et al “Obstacle-avoiding robot with IR and PIR motionSensors” IOP Conference Series: Materials Science and Engineering, vol. A247, pp. 529-551, April 2005.

[3] Vaghela Ankit¹, Patel Jigar², Vaghela Savan³ “Obstacle Avoidance Robotic Vehicle Using Ultrasonic Sensor, Android And Bluetooth For Obstacle Detection” International Research Journal of Engineering and Technology (IRJET), vol. A247, pp. 29-32, 2005.

[4] Paul Kinsky,Quan Zhou “Obstacle Avoidance Robot” Worcester polytechnic institute.

[5] FaizaTabassum, SusmitaLopa, Muhammad MasudTarek& Dr. Bilkis Jamal Ferdosi “obstacle avoidance car”Global Journal of Researches in Engineering: HRobotics & Nano-Tech.

[6] Bhagya shree S R , Manoj kollam “Zigbee Wireless Sensor Network For Better Interactive Indus

WEBSITES:

- <https://www.ijcaonline.org/archives/volume56/number5/8885-2882>
- <https://ieeexplore.ieee.org/document/4725791>
- <https://www.sciencedirect.com/science/article/pii/S1877050917302107>
- <http://www.datasheetcatalog.com>
- <http://www.instructabal.com>
- http://en.wikipedia.org/wiki/Artificial_intelligence
- <http://science.howstuffworks.com/robot2.htm>
- <http://arduino.cc/en/Main/arduinoBoardUno>

Magazines:

- Electronics for you
- Electronic Hub